

Mech Masz

Szczeciński
sp. z o.o. sp.k.



Bread cutting and packaging line

Automatic and Semi automatic lines

EFFICIENT AND COMPACT LINE FOR CUTTING AND PACKING DIFFERENT TYPES OF BREAD

WATCH OUR
VIDEO ON
THE WEBSITE





Four movable bread guide bands



Movable collecting band with a feeding sensor



Line version with one or two blowing tables



**FULL
EQUIPMENT
AS A STANDARD**

COMPACT DESIGN

SPACE SAVING

CUTTER WITH BAND KNIVES



AUTOMATIC PACKING STATION SPA-3000

An optional rotary table – a storage of a packed product

Key functions

all as a standard

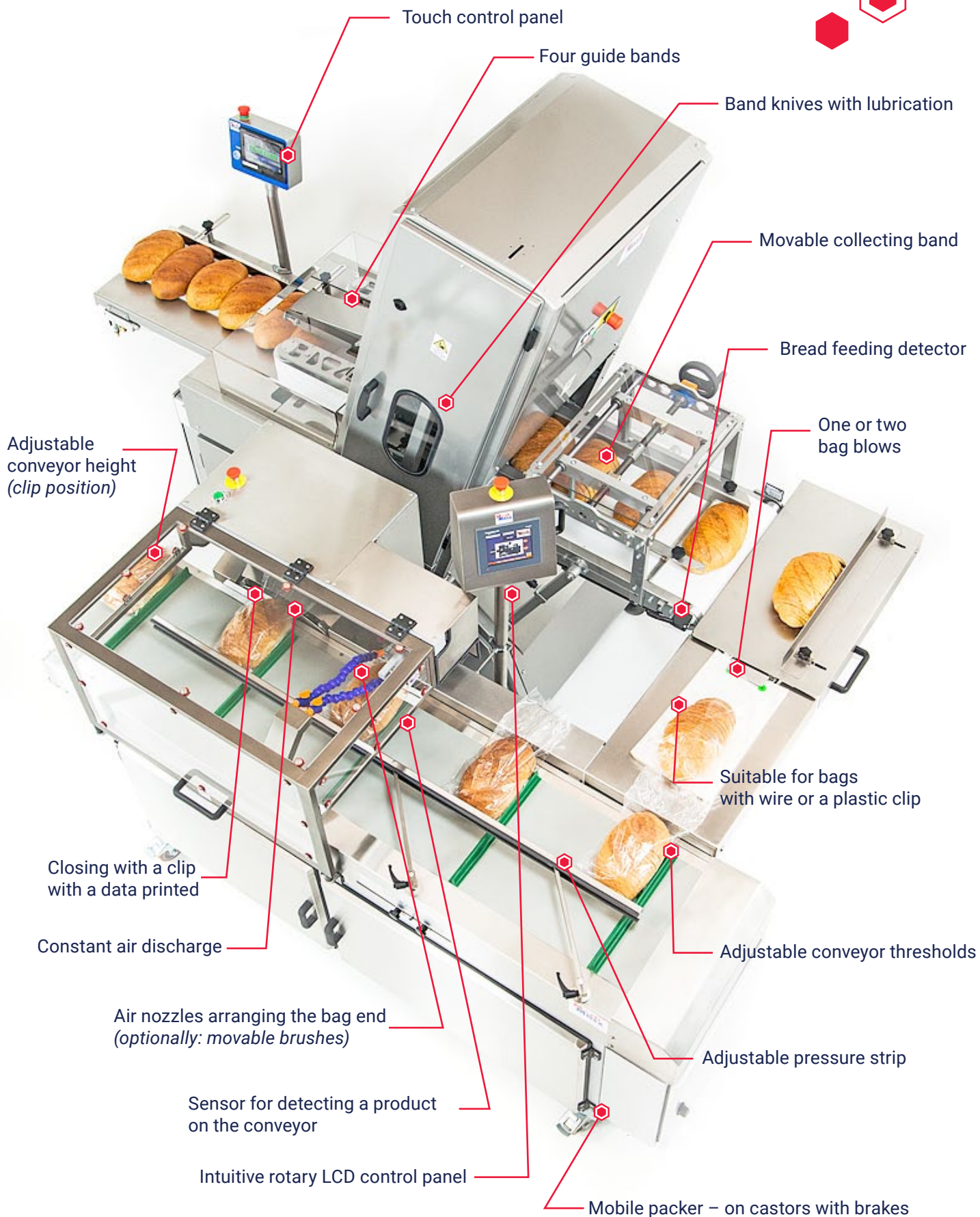

CUTTER WITH BAND KNIVES

Maximum capacity

The capacity of 2500 bread loaves 0.6 kg each per hour, depending on the type of bread, baking and cooling degree. It is designed as a standard for a 11 mm thick slice of bread. With the knife guided in a proper way, constant slice width can be maintained.

The machine is equipped with 167' long band knives of a long service life, which are easy to replace. It has been designed

for connection with the automatic packing station **SPA-3000**. Products are fed with the top, bottom and side bands, whose speed is adjusted directly from the LCD panel using an inverter.

By default, the cutter features synchronisation of bread loaf collection, one by one, up to the packing line (*detector at the outlet*).

even
2500
loaves/h

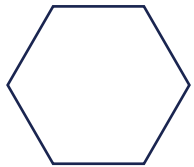

Characteristics

- For every type of bread.
- 4 guide bands: 2 side, 1 top and 1 bottom as a standard for effective bread cutting.
- Knife lubricating system with nozzles as a standard. Lubricating force adjustable directly from the LCD panel.
- Maximum length of a cut bread: 400 mm.
- Manual feeding of a product onto the conveyor (*possible synchronisation with the conveyor*).
- 11 mm knife span – by default (*another on request*).
- Band knife drum with adjustable tension. Easy knife replacement.
- Band knife guide made of hardened metal to a specific bread slice thickness.
- Light sensor at the bread outlet of the machine.
- Broken knife sensor – machine stop.



TECHNICAL DATA

Drive power: 4,18 kW, inverter controlled
Dimensions: 876 x 2090 x 2000 H [mm]
Weight: 770 kg
Connection: 3 x 400 V – 50/60 Hz
Control voltage: 24/12 Volt

AUTOMATIC PACKING STATION

SPA-3000

For closing foil bags with a packed product. A product is put manually in a pre-blown bag and placed on a transverse feeding band. In further steps, excess air is removed from the bag which is then closed with a wire clip. The ready product closed in this way may be taken off manually or collected on the rotary table.



- Detector recognising a product (manual or automatic operation) and a blank field (saving on clipping band).
- Adjustable blowing fan power at bag blow.
- Air nozzles arranging a bag and initially removing excessive air.
- Vacuum function – possible extension of the release time.
- Lifted and lowered feeding table, positioning a clip for bread loaves.
- Shift work counter, total counter.
- Automatic machine turn off in case of no 'work' performed – power saving.
- Programming a set number of bread loaves for packing.
- LCD control, touch panel, alarms displayed on the control panel.
- Protection of the clipping zone with a transparent cover.
- Housings made of high quality stainless steel AISI 304.

TECHNICAL DATA

PACKING SCOPE

(product dimensions)

Width: 100 – 250 mm

Length: 140 – 420 mm

Height: 50 – 160 mm

Capacity: up to 45 packages/min
(depending on the product and bag)

OUTER DIMENSIONS

(model with one blowing table)

Width with blow: 1435 mm

Length: 2150 mm

Height: 1210 mm

Weight: 340 kg

Electric power: 1 KW

Voltage: 400 Volt, 50 Hz

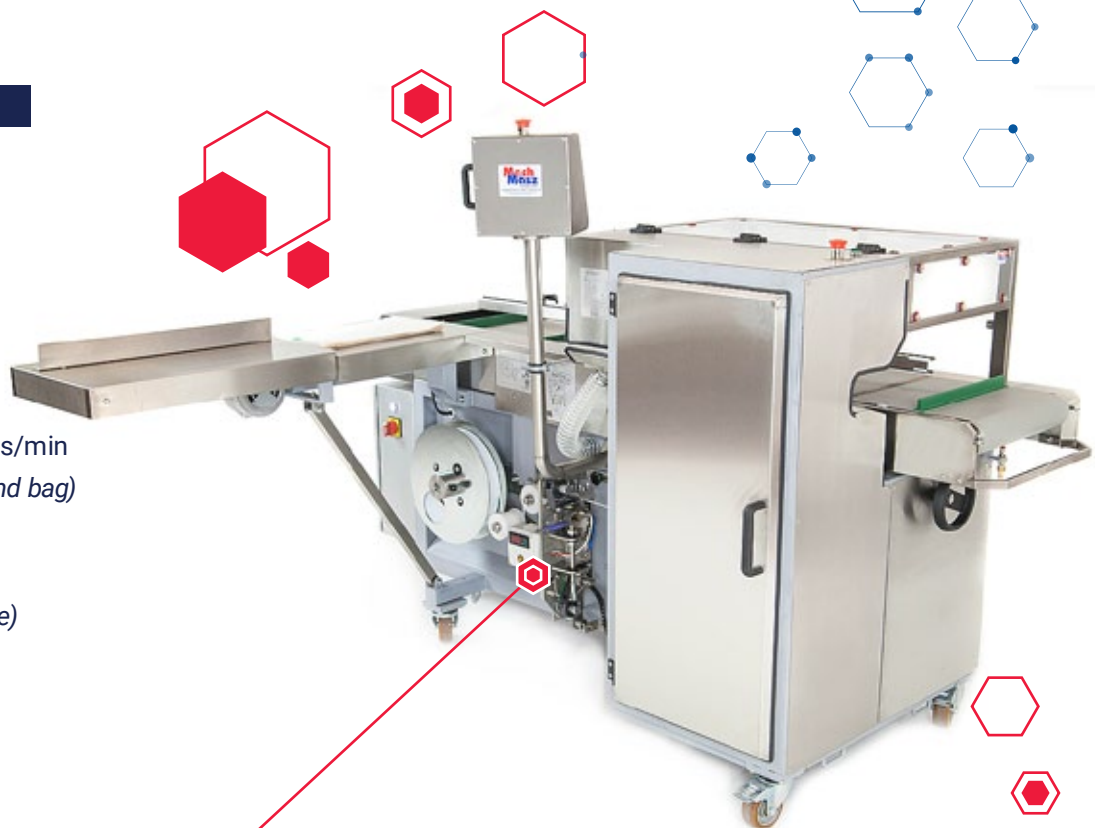

Professional printer with a rotary drum



Clipping zone



LCD panel control

Two operating modes: manual and automatic

WATCH OUR VIDEO ON THE WEBSITE



Subskrybuj nasz kanał YouTube

ESTIMATED WORKSPACE

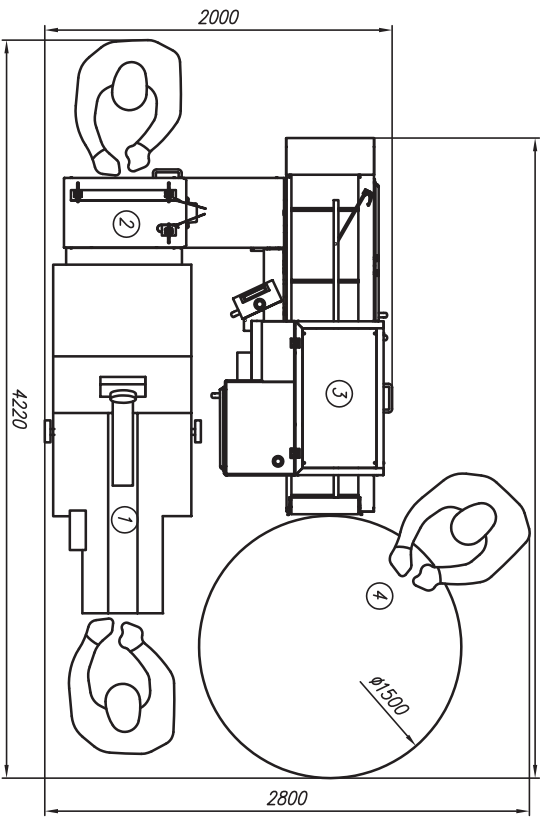

CONFIGURATION WITH ONE BLOWING TABLE

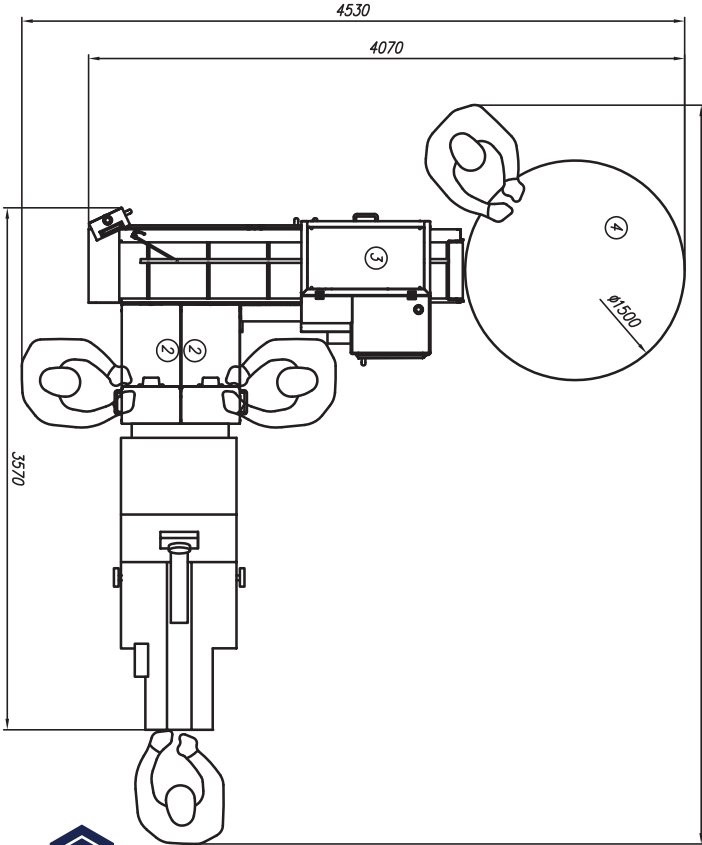

CONFIGURATION WITH TWO BLOWING TABLES

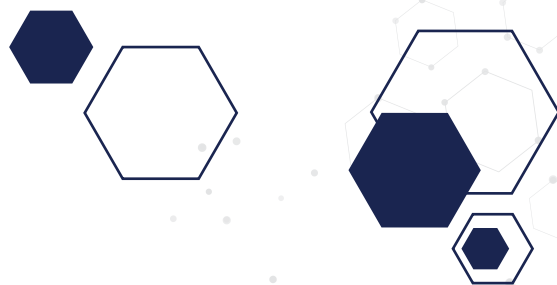

Leader in the industry

MECH-MASZ Szczeciński Sp. z o.o. Sp. k. established in 1986 is an industry leader of Polish manufacturers of bakery and confectionery machines.

- For 33 years, services tailored to customer needs and perfect quality of products have been the main features making the MECH-MASZ brand stand out.

We participate in all major bakery and confectionery fairs in Poland and Europe. We organise annual meetings for bakers and confectioners, while offering our baked goods and presenting the registered office. At present, the company manufactures more than 50 models of devices, and the full range includes about 800 products.

Our products are sold to domestic market customer and exported to more than 30 countries worldwide.



The company is ISO 9001:2015 certified.

**Mech
Masz**
Szczeciński
sp. z o.o. sp.k.

You're investing in future

MECH-MASZ Szczeciński
spółka z ograniczoną odpowiedzialnością sp.k.

 Jaroszewo 80
88-400 ŻNIN
POLAND

 export@mech-masz.com.pl
mechmasz@mech-masz.com.pl

 tel.: +48 (52) 302 00 73
tel.2: +48 (52) 303 12 38
tel.3: +48 (52) 303 12 39

www.mech-masz.eu